

WEST WIGHT POTTER 19

USER'S GUIDE

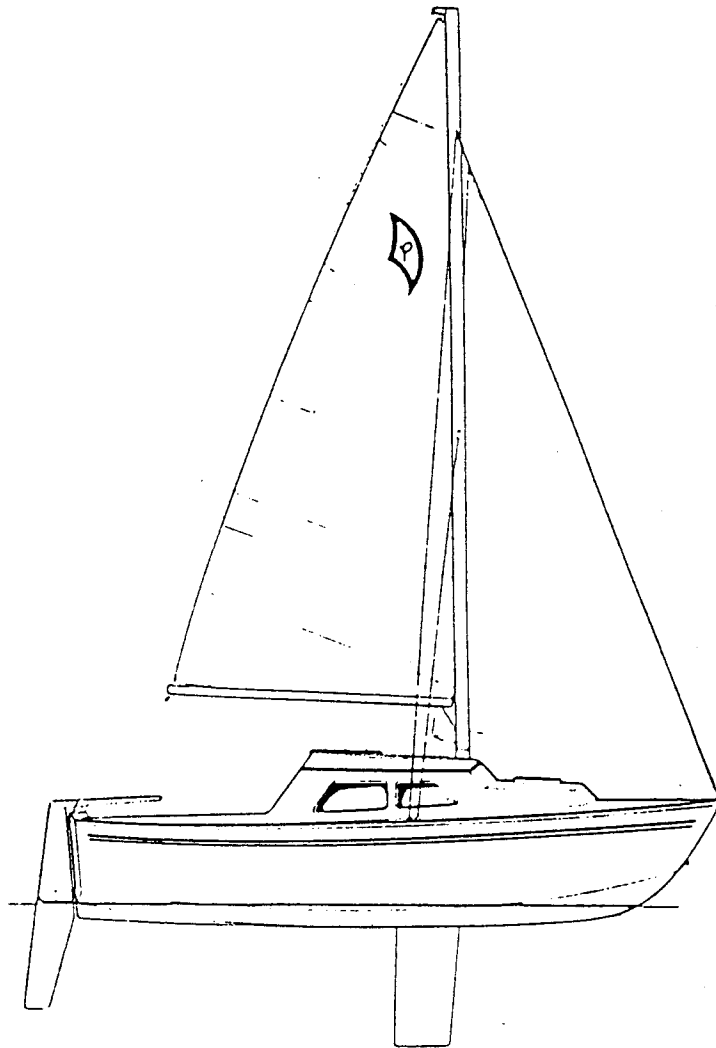

INTERNATIONAL MARINE
904 West Hyde Park Blvd.
Inglewood, CA 90302
(310) 674 5959

INTRODUCTION

Congratulations! You have purchased one of the best known trailerable pocket cruisers available.

In this Users Guide you will find information and instructions to help you get the most out of your Potter. West Wight Potters are designed to be the easiest of boats to trailer, rig, launch and sail. This users guide is not intended to provide sailing instructions. We recommend that you should consult books written for that purpose or take sailing lessons or courses to gain the knowledge necessary for the safe operation of your West Wight Potter.

The instructions that we give in this Users Guide are what we consider to be the easiest way to rig, and get the most out of, your boat. However, as you sail your Potter you will, no doubt, find routines that suit your use of the boat, the launch ramps you use and your crew!

If we can assist you at any point, give us a call:

1-800 433 4080

Happy Sailing!

**International Marine
Manufacturers of the West Wight Potter**

TABLE OF CONTENTS

Rigging Your New Boat	Page 2
Launching The Boat	Page 5
Raising The Sails	Page 6
Sail Options	Page 7
Safety Equipment	Page 9
Trailerling	Page 10
Motoring	Page 11
Optional Equipment	Page 13
General Maintenance	Page 16
Warranty Details	Page 17
Mast Specifications	Page 18
Boom Specifications	Page 19

GETTING YOUR NEW BOAT READY

When your new Potter arrives it may need a quick wash. Check your purchase order to verify everything is there. You are now ready to rig your boat.

At this point several items may need to be assembled on a one time only basis before your first launch and sail. These items will then be left permanently connected for your convenience. Your rudder should also be assembled now. Install tiller handle using thru-bolt with the curve of the tiller facing up. Tighten nut to allow the tiller to swing up and down freely without being overly loose. Disconnect the rudder when not in use and store in an extended position, tiller arm first, on the floor of the cabin. When using the kick-up rudder maintain a little tension on the port extension line and cleat as you pull on the starboard kick-up line and cleat - this prevents the extension line from losing its center alignment (practice makes perfect). It might also save you time later at the launch if you do a few things now like connecting the sheets to your jib/lapper/genoa and tying the shackles to the halyards.

Rigging Your New Boat

Mast Raising. (When up to speed, 5 minutes to launch)

Step One: Disconnect tie down straps and stow safely.

Step Two: Unwrap mast and connect side stays. Upper stays connect to the chain plate at side of boat in aft hole; Lower stays connect at forward hole (See Fig. 1).

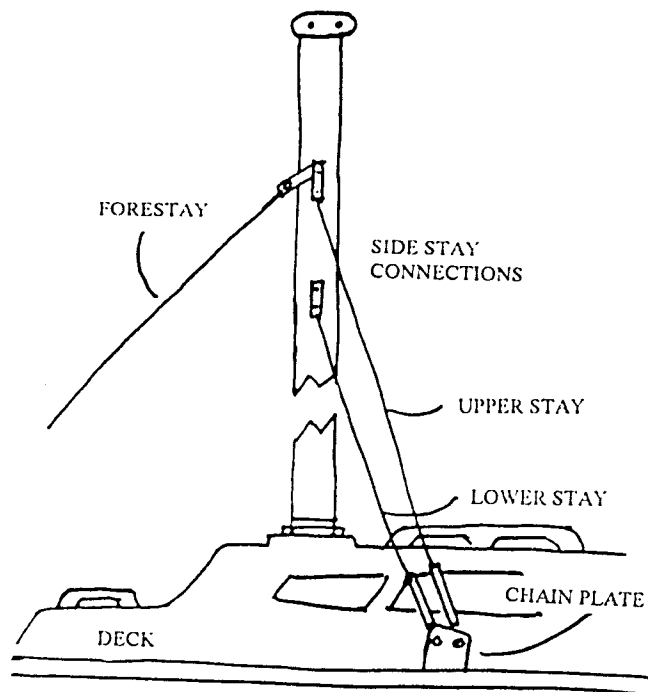

SIDE STAY CONNECTIONS
(Figure 1)

Step Three: Set mast crutch at uppermost position. Close main hatch, disconnect pin at bow pulpit, walk mast aft and insert pivot pin in rear hole of mast step on cabin top.

Step Four: Before raising the mast check the four side stays for twists. Also, check for overhead obstructions.

Step Five: With one person either side of the mast facing each other raise the mast from the cabin top. Keep mast on the vertical while raising. (For additional ease of raising a third person can stand on bow and pull on forestay) Before raising mast last several feet, check to see that turnbuckles and stay adjuster are in alignment and not binding.

Step Six: When mast is upright connect forestay. The second pin can now be inserted in the mast step.

Step Seven: Tune rig if needed by tightening turn buckles and forestay to achieve a vertical mast as viewed from stern and beam. Make sure stays/shrouds are tense but not overtight.

IMPORTANT NOTE: To maintain tune and prevent loss, tape or wire turnbuckles.

Optional: Mast Raising System (See Fig. 2)

If you are going to be sailing single handed we recommend you consider the Mast Raising System. If you have it fitted, follow these directions:

Step A: Disconnect tie down straps and stow safely.

Step B: Disconnect pin at bow pulpit, walk mast aft and reinsert the pivot pin at rear of mast step.

Step C: Connect upper and lower stays to chain plate. Upper stays connect to the chain plate at side of boat in aft hole. Lower stays connect at forward hole (Fig. 1). Connect special stays (mini stays) and fulcrum pole using lowest through bolt from the top of the mast. Adjust block at top of fulcrum pole to port (left). Connect mini stays to U-bolts on cabin top. Do not tension mini stays, they should remain loose to work effectively.

Step D: The 50' x 5/16" hoisting line will come connected to a block and becket with a shackle. Connect jib halyard to the shackle, remembering to cleat jib halyard at mast. Take hoisting line down to double block on bow pulpit, back up to block with the becket then back to the double block, back through the jam cleat on the cabin top into the cockpit. From cockpit raise mast by pulling the hoisting line with the left hand while pushing the mast up with the right hand.

Launching the boat

A General Word About Launching

The following steps are based on a situation where the launch ramp is typically steep with a dock next to the ramp. However, there are other launch ramp situations that necessitate other procedures and possibly the use of tongue extenders - if you need advice please call IM. Basically, there are no hard rules for launching and if you find a system that works for you, use it. Some sailors launch then rig their sails, others have their sails already rigged and ready to be raised. It is entirely up to you. One word of advice - it might prove less harrowing if your first launch isn't at a peak time on a holiday weekend!

Step One: Tie dock lines to stern and bow of boat, tie on fenders.

Step Two: Disconnect safety line from bow eye and trailer winch strap.

Step Three: Slowly back trailer and boat into the water until trailer is submerged and boat floats free. When launched, turn boat into wind (if possible) and tie to dock.

Step Four: Lower center board* and install rudder.

Step Five: Connect boom to mast by inserting gooseneck into the slot in the mast. and attach the topping lift (3/16" line on mast) to the eyestay on the end of the boom using the snap shackle.

Step Six: You can now connect the main sheet (See Fig. 3). Tie off the 1/4" X 38' line at the becket of the block on the starboard (right side) of the transom (back of the boat). The line is then led up to the double block on the boom end, back down to the block with becket, up to the double block again, down to the block on the port (left side) of transom, through the bullseye fairlead and through the jam cleat.

***IMPORTANT:** DO NOT ALLOW THE KEEL CABLE TO BECOME SLACK. IF THIS HAPPENS, CHECK DRUM FOR CABLE FOULING AND CAREFULLY WINCH CABLE CLOCKWISE MAINTAINING TENSION ON THE CABLE.

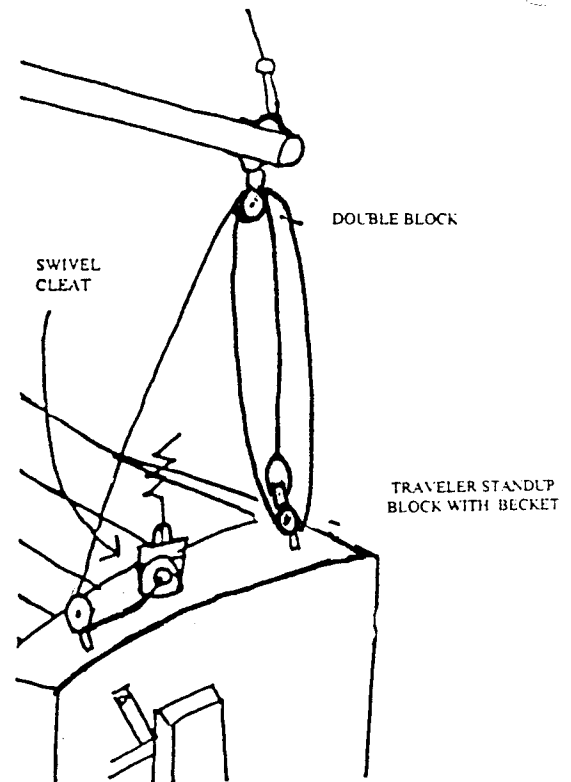

MAINSHEET CONNECTION

(Figure 3)

Raising the Sails

Main Sail

Step One: Tie shackle to starboard halyard and connect shackle to head of sail, then install battens in sail in the corresponding pockets. Connect tack and clew of foot to boom. (See Fig. 4))

Step Two: Thread luff (leading edge of sail) into mast slot and hoist sail making sure luff does not bind in slot. Cleat halyard and coil excess line and secure at horn cleat.

Step Three: Cleat main sheet loosely allowing boom to move freely in the wind.

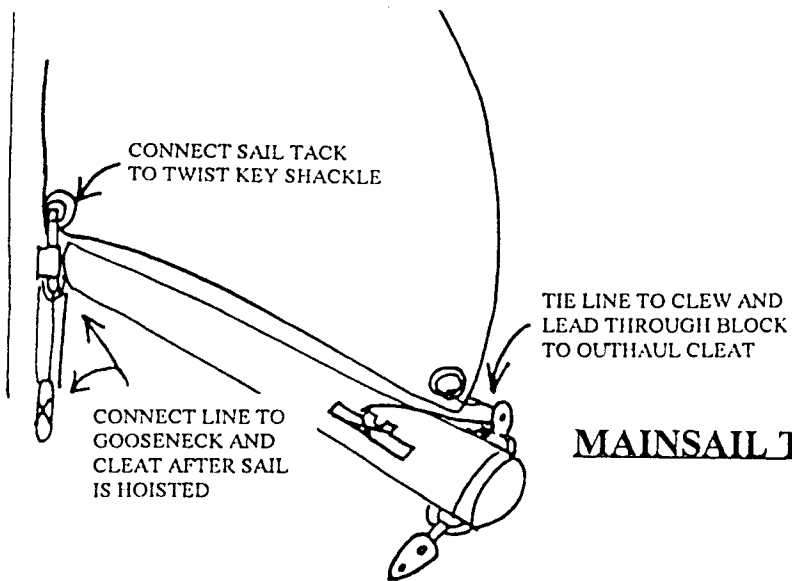

MAINSAIL TO BOOM CONNECTION
(Figure 4)

Jib Sail

Step One: Tie shackle to jib halyard, connect shackle to peak of sail, connect jib hanks on forestay and connect tack with shackle provided.

Step Two: Fold jib sheet in half. Run loop through clew and free ends back through loop, and lead free ends aft outside stays through the standup blocks on deck and then to jam cleats on cockpit combing.

Step Three: Hoist sail with more tension on luff (leading edge of jib sail) than on forestay. Cleat halyard and coil excess line and secure.

OTHER SAIL OPTIONS INCLUDE:

Lapper Sail

This general purpose sail, most popular of all the available sails, is the middle size front sail between the standard jib and the larger genoa. Raise the sail just as you would your standard jib.

Genoa Sail

This is the largest front sail and is used in light air conditions and for greater speed. Raise this sail just as you would your other front sails. Rigging genoa sheets: Lead genoa sheets aft on either side outside stays bypassing jib standup blocks to genoa track and car blocks. Then lead back to jib standup blocks and then to cleat (See Fig. 5).

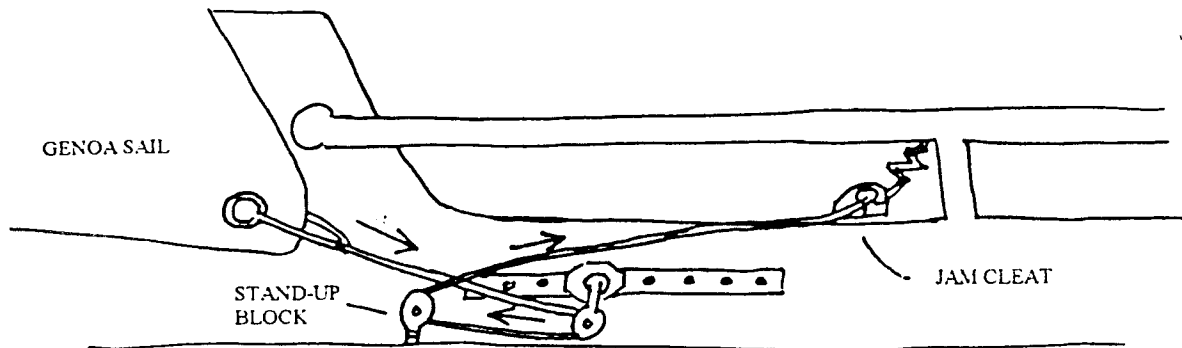

GENOA TRACKS & BLOCKS

(Figure 5)

Genoa Whisker Pole

An adjustable aluminum pole with a special quick release fitting 24" up from the base of the mast. This pole is best used when sailing down wind as the pole holds the sail in its straight out position for greater speed and control. The pole also allows the genoa sail to simulate much of the effect achieved with a Spinnaker sail.

Spinnaker Sail

This multicolored, large balloon type sail is used mainly for sailing down wind and is characterized by its large billowing shape pushing out in front of the boat. The spinnaker raises just like the front sails but on it separate mast hoisting line and the sail control lines lead back to horn cleats at rear of boat. No special adjustment is needed for down wind sailing - just ensure the sail is full of wind. The spinnaker, although used less frequently in sailing, is certainly one of the most beautiful sails you can have for your Potter. This light weight sail is also frequently seen in racing events. (See Fig. 6)

Spinnaker Hardware and Pole

This option greatly increases the effectiveness of your spinnaker. Included in the option, a special halyard line for raising the spinnaker on the mast and a properly sized quick release spinnaker pole which connects between one end of the spinnaker and the mast. A line from the deck up to the pole will hold the pole in a level position. Although a little more attention and skill might be needed to operate the spinnaker and accessories, once mastered, you will have the same skills used with the largest spinnakers on the fastest off shore cruising yachts. (See Fig. 6)

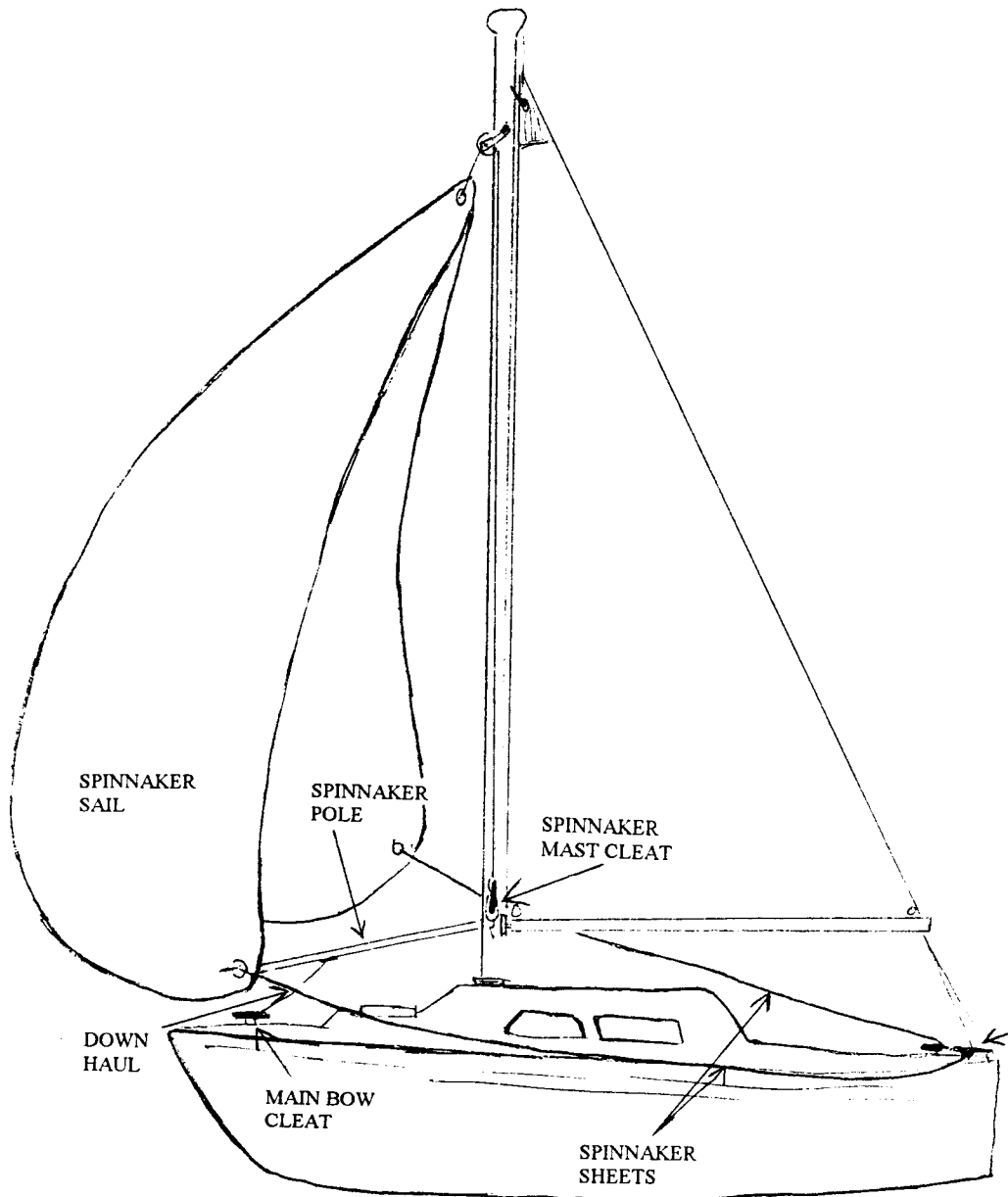

SPINNAKER SAIL, HARDWARE & POLE
(Figure 6)

SAFETY EQUIPMENT

You must comply with Coast Guard regulations when sailing and there is a minimum of safety equipment required which we have listed below.

Federal Law says you must have the following aboard for any boat less than 26 feet:

1. *LIFE JACKETS*

One type I, II, III or Hybrid Type V for each person on board (Hybrid Type V must be worn at all times to meet Coats Guard regulations).

2. *FIRE EXTINGUISHERS*

At least one B-1 Coast Guard approved type hand portable fire extinguisher.

3. *WHISTLE, BELL, OR HORN*

Any device capable of making an "efficient sound signal" audible for 1/2 mile.

4. *VISUAL DISTRESS SIGNALS* - for coastal waters, Great Lakes or high seas
Orange flag with black square-and-disc; and an S-O-S electric light; or 3 orange smoke signals, hand held or floating; or 3 red flares of handheld, meteor, or parachute type.

Obviously there are other things you should carry such as a paddle, a first aid kit, a tool kit, extra batteries if any of your emergency equipment is battery driven, extra clothing and a small portable radio to check weather reports. You might also consider a VHF radio or a cellular phone.

ANCHORS

Another item you may wish to obtain is an anchor. Different types of anchors are available for different sea bed conditions. Choose carefully for the type of sailing you will be doing. A bow roller should be installed to protect your boat from scraping from the anchor chain. Your anchor can be mounted on your front bow rail or front boat deck with the opposite end of the anchor line through the air vent to the anchor attachment plate provided in the front anchor line compartment, reached from inside the cabin. Some sailors prefer to keep the chain and rode connected permanently and store the anchor below for convenience. When using your anchor have enough line so the angle of the line from the boat to the sea (scope) is about 45° or more.

TRAILERING MADE EASY

Your Potter will be a joy to trailer with its light overall towing weight and low trailering height. The high speed tires and wheels on your trailer are supplied with Bearing Buddies to ensure ultimate serviceability when backing your trailer into the water. Using a hand grease gun with automobile type fitting obtainable from your hardware or automotive store, apply grease through the fitting in the center of the wheel until the visible diaphragm moves outward slightly. Usually grease fittings are greased according to your use (these should be checked regularly).

When trailering at highway speeds tie-down straps should be used. The tie-down should be connected to both sides of the trailer frame while going across the cock-pit of your Potter.

The most important points to check before trailering would be:-

- tongue hitch latched firmly to car towing ball
- trailer safety chains connected to car
- electrical plug connected to trailer for proper lighting
- mast in down position and secured to boat
- stays/shrouds securely coiled below mast
- tie-down strap firmly attached
- trailer winch strap connected and tightened to bow eye with additional safety line
- right and left rear view mirrors checked for position
- rudder placed in cabin or cockpit
- all equipment and accessories on board.

You will need a 2" ball and a standard 4-prong flat plug. Most trailer hire companies will also supply and fit your hitch connection.

MOTORING FORGET THE SAILS, FULL STEAM AHEAD

With the Potter's flatter hard chine hull configuration excellent motoring performance may be obtained from a smaller, less expensive motor. For the Potter 19 a 3.5hp-5.0hp long shaft motor is typical. If you haven't already bought your motor we can advise you.

With your motor tightly clamped to the motor mount and a securely fastened chain or line fitted for additional security you are ready to motor away. The most important factors to remember before starting your motor are:

- lower the kick-up rudder if fitted on your boat
- open fuel tank air vent (either on top of motor or on top of external tank)
- open fuel ON-OFF valve on side of motor
- shift gear to neutral (if provided)
- set choke and correct throttle position for starting
(NOTE: If the choke and throttle are not correctly set before pulling the starting rope the motor may be "flooded")
- pull the starting rope with a strong, straight, back force while simultaneously holding firmly to the boat.

For steering you generally want to leave the motor pointed directly ahead, steering with the rudder. Your motor has a friction screw which may be tightened to prevent your motor from turning inadvertently when steering.

Remember, when motoring you have to yield to other boats that are under sail alone as they have the right-of-way. When possible run your motor at about 1/2 to 3/4 throttle to obtain best cruising performance. If your motor has an internal tank you should carry an auxiliary gas can for emergencies.

You will find a lot of interesting ways to use your motor to make your sailing more enjoyable. For example, there may be a destination which might necessitate an early morning start. Without wind you could motor then, with the first breezes, switch to sail. The motor would prove to be useful for exploring narrow inlets and channels, for getting into busy, congested dock areas or for slow speed while fishing. The motor will add an additional dimension to your enjoying your new Potter.

HEADING HOME WITH YOUR BOAT IN TOW

Before getting your boat out of the water and onto its trailer take the sails down and raise the keel. Install the keel support bolts and lower the keel slightly to relax the keel cable.

With the trailer as far back into the water as possible, float your boat onto the trailer pulling with the front dock line connected to the boat. With a little practice this will become quite easy. With experience you will be able to nudge your boat slightly while on dock and while guiding the front and back deck lines be able to lead the boat directly onto its trailer. Without a dock you will want to lead your boat by standing on the trailer tongue. When the boat "catches" the trailer support cushions, you may then connect the trailer winch hook to the boat's trailer eye and crank firmly until the front of the boat touches the upright support on the trailer.

Driving your boat and trailer directly up the ramp, proceed to the closest level location to lower your mast (reverse of raising) and reinstall the trailer tie-down lines or straps for highway trailering. Double check that your mast and all loose lines are secured so nothing dangles over the side which might interfere with trailering. Remember to re-connect the trailer electrical plug.

As a rule of thumb never disconnect anything unless it is absolutely necessary to get your boat home. Your main sail may easily be left connected to the boom and, with all battens installed, still fit inside the cabin. Also, all sail lines are extra length and can be left connected to the mast and led under the cabin door.

Mast transport: Secure the mast and stays for transport by a) coiling the stays together in a continuous loop without binding and tie below the mast using short lengths of light line. Tie to mast inside the halyards to prevent chafing. b) Tie mast to crutch at "Y" and where the gudgeon and pintle intersect to prevent the mast from bouncing up and down. c) If you boat has a jib roller furling system tie the foil below the mast using short lengths of line taking care to tie the drum to the mast to prevent undue stress on the foil and drum.

OPTIONAL EQUIPMENT

At this point we have covered all aspects of operating your standard Potter. Although your standard Potter includes everything needed to sail and trailer away certain items are available as optional extras. Call International Marine for further information.

Jiffy Reefing System - In addition to the reefing points in the sail, the Jiffy Reefing system includes lines which go up through the front and rear reefing grommet holes and back to a convenient cleating area. With the system installed all the time you can quickly reef your sail. (See Fig. 6)

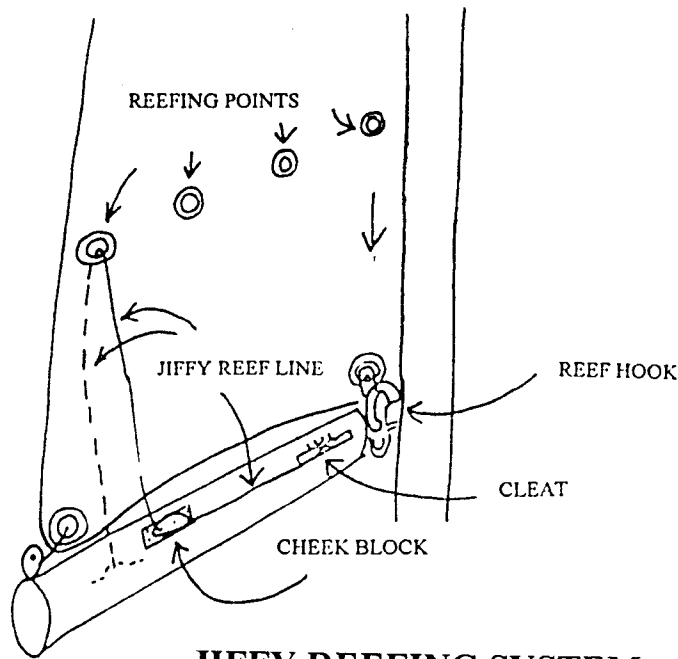

JIFFY REEFING SYSTEM
(Figure 7)

Genoa Winches & Crank - This options includes #6 Harken winches and extra cleats midships to ease the control of the genoa (See Fig. 8)

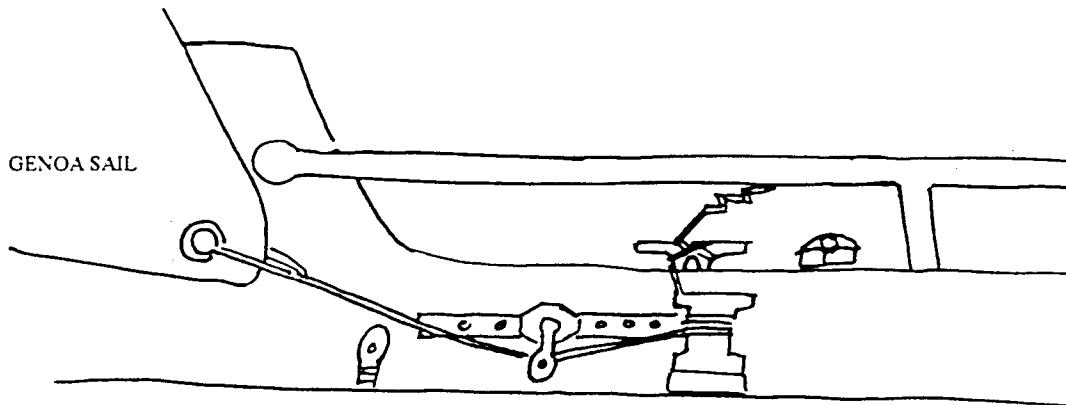

GENOA WINCHES
(Figure 8)

Genoa Whisker Pole - An adjustable aluminum pole with a special quick release fitting 24" up from the base of the mast. This pole is best used when sailing down wind as the pole holds the sail in its straight out position for greater speed and control. The pole also allows the genoa sail to simulate much of the effect achieved with a Spinnaker sail.

Boom Vang - The boom vang consists of an adjustable line with a reduction type locking block between the base of the mast and angling upward to approximately one-third of the way back on the boom. Designed to place a downward force on the boom and correspondingly flattening the mainsail, the boom vang is especially useful to ensure a flatter sail area in down wind sailing conditions. Although you will spend a little extra time in connecting the boom vang fittings before sailing, the boom vang remains one of the most requested options for the Potter. (See Fig. 9)

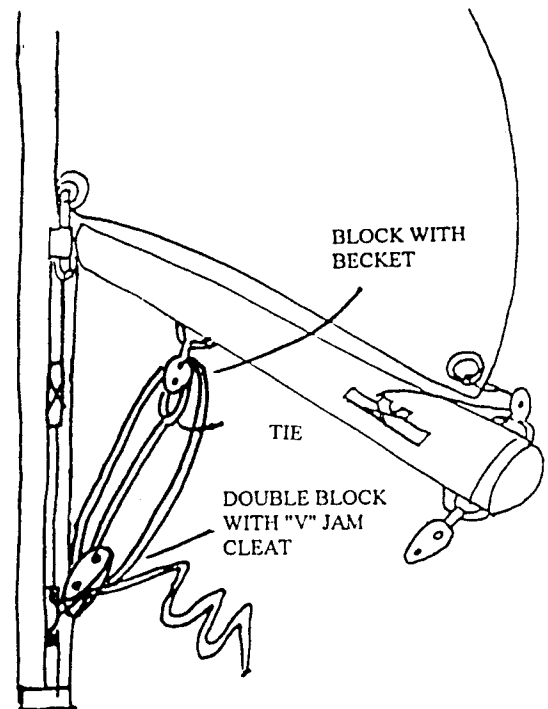

BOOM VANG
(Figure 9)

CDI Foresail Roller Furling - This is a roller furling system which can also be used as a foresail reefing system. We use a Cruising Design Inc. product specifically designed for smaller sailboats. This option is especially good if you are going to keep your boat moored as it takes away the necessity of removing your jib/lapper or genoa each time. The option comes with a fully illustrated "how to use" guide **which should be read thoroughly before use**. We would also add that a safety line should be tied from the furling drum to the forward deck when raising mast. When trailering the drum and luff foil should be tied against the mast to prevent undue stress.

Mast Topping Lift - A light line which loops to the top of the mast and back to a tie-off cleat, this option is useful as it holds the boom in place when the sails are down. It can also be useful for gaining access to the top of the mast i.e.. raising racing flags and pennants.

Canvas Items - We also have a wide range of canvas items available for the Potters. These include a complete boat cover, sail cover, bimini top and dodger. All made with Sunbrella material, they are all specifically designed for the Potter boats.

GENERAL MAINTENANCE

The West Wight Potter is designed to be a low maintenance sailing boat. You will, of course, have to do regular checks on the rigging, checking the halyards/stays/shrouds for fraying and wear. Before every sail you should do a rigging inspection, checking turnbuckles, clevis pins, gooseneck, tangs on the mast and halyards.

If you do any salt water sailing the boat should be rinsed thoroughly when you retrieve it with fresh water, you should also rinse the motor if you use it.

BOAT CLEANING

Once or twice a year your boat hull will need to be cleaned and polished. There are several very good products on the market that clean, de-oxidize and polish in one, a sealant should then be applied.

The teak trim can easily be cleaned with TSP (Spic and Span) and warm water using a stiff brush or green scouring pad. Dark stains can be bleached with Oxalic acid. The wood can then be finished with teak oil applied with a brush or a rag. Don't over apply the teak oil and care should be taken to wipe up any excess to avoid staining the gel coat.

SAIL MAINTENANCE

Before each sail you should visually check your sails for any signs of wear, chafing small rips etc.

Sails should never be put away wet. If they are wet after sailing, leave them in loose bundles and dry them at your first opportunity.

For most common problems such as dirt, dried or caked salt try scrubbing the surface with a soft bristled brush and liquid detergent. Avoid harsh powder detergents and stiff brushes as they may damage the finish or stitching. This approach should work very well for most stains.

TRAILER MAINTENANCE

You should regularly check the tire and tire pressure on your trailer. Your trailer is supplied with Bearing Buddies and you should regularly grease the axle using a marine wheel bearing grease gun. Grease guns are readily available at any auto supply store, however please check that they are of marine quality.

You should also regularly check the tie-down straps for wear.

WARRANTY

The following warranty applies to all new boats:

LIMITED WARRANTY

West Wight Potter 19

All fiberglass parts (Hull, Deck, and Liner) are guaranteed against any defects in workmanship for a period of 3 (three) years from the original date of purchase, to the original owner listed by the manufacturer/factory. All other parts and accessories purchased and installed by the manufacturer/factory as original equipment are covered by the original manufacturers guarantee, not to exceed one year. Any defective fiberglass or parts must be returned FOB, where possible, to factory for either replacement or repair at factory's discretion. Normal wear and tear, neglect, misuse or abuse are not covered by this warranty.

904 West Hyde Park Blvd., Inglewood, CA 90302

INTERNATIONAL MARINE

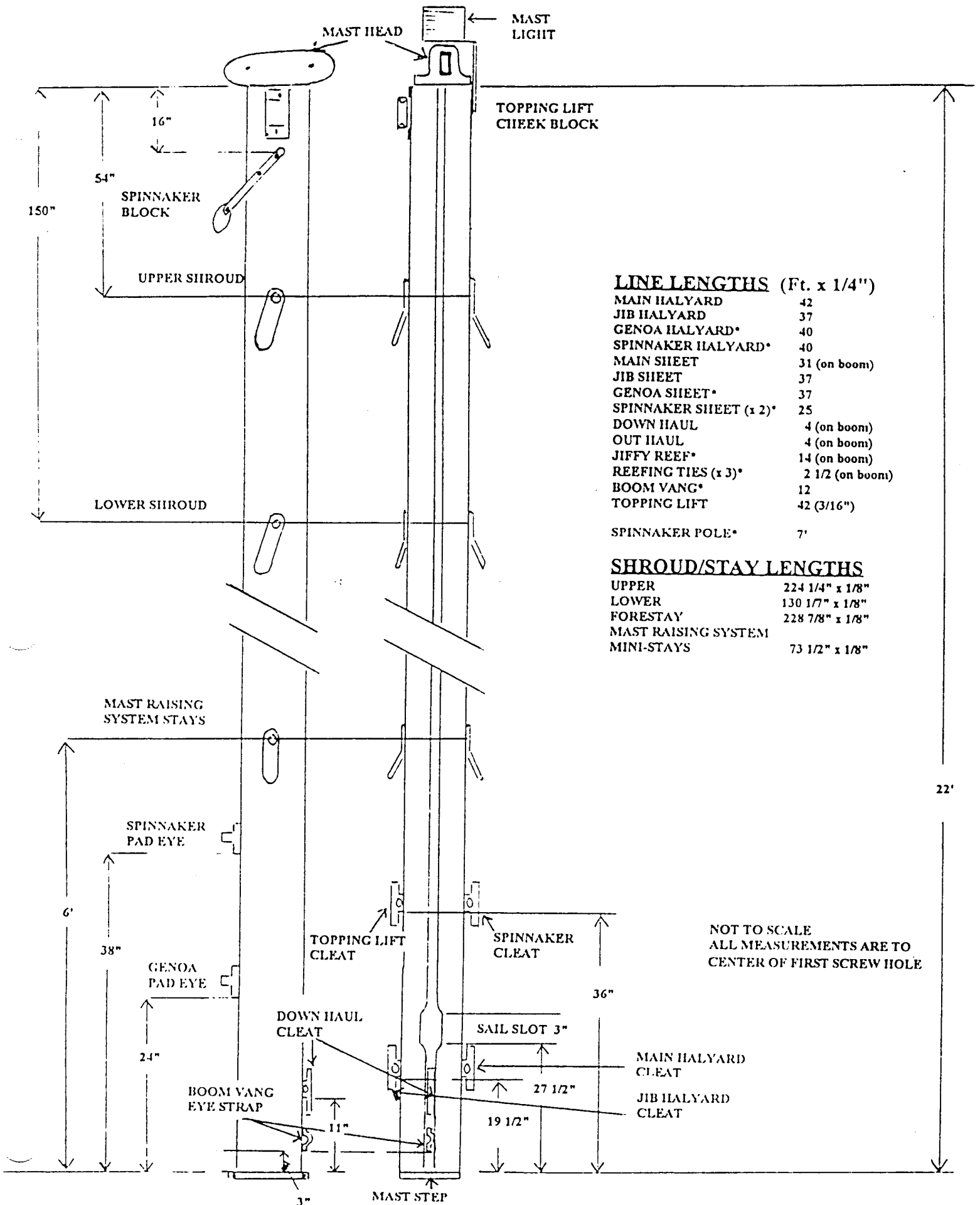

TOPPING LIFT
CHEEK BLOCK

LINE LENGTHS (Ft. x 1/4")

MAIN HALYARD	42
JIB HALYARD	37
GENOA HALYARD*	40
SPINNAKER HALYARD*	40
MAIN SHEET	31 (on boom)
JIB SHEET	37
GENOA SHEET*	37
SPINNAKER SHEET (x 2)*	25
DOWN HAUL	4 (on boom)
OUT HAUL	4 (on boom)
JIFFY REEF*	14 (on boom)
REEFING TIES (x 3)*	2 1/2 (on boom)
BOOM VANG*	12
TOPPING LIFT	42 (3/16")
SPINNAKER POLE*	7'

SHROUD/STAY LENGTHS

UPPER	224 1/4" x 1/8"
LOWER	130 1/7" x 1/8"
FORESTAY	228 7/8" x 1/8"
MAST RAISING SYSTEM	
MINI-STAYS	73 1/2" x 1/8"

NOT TO SCALE
ALL MEASUREMENTS ARE TO
CENTER OF FIRST SCREW HOLE

PI9 BOOM SPECIFICATIONS

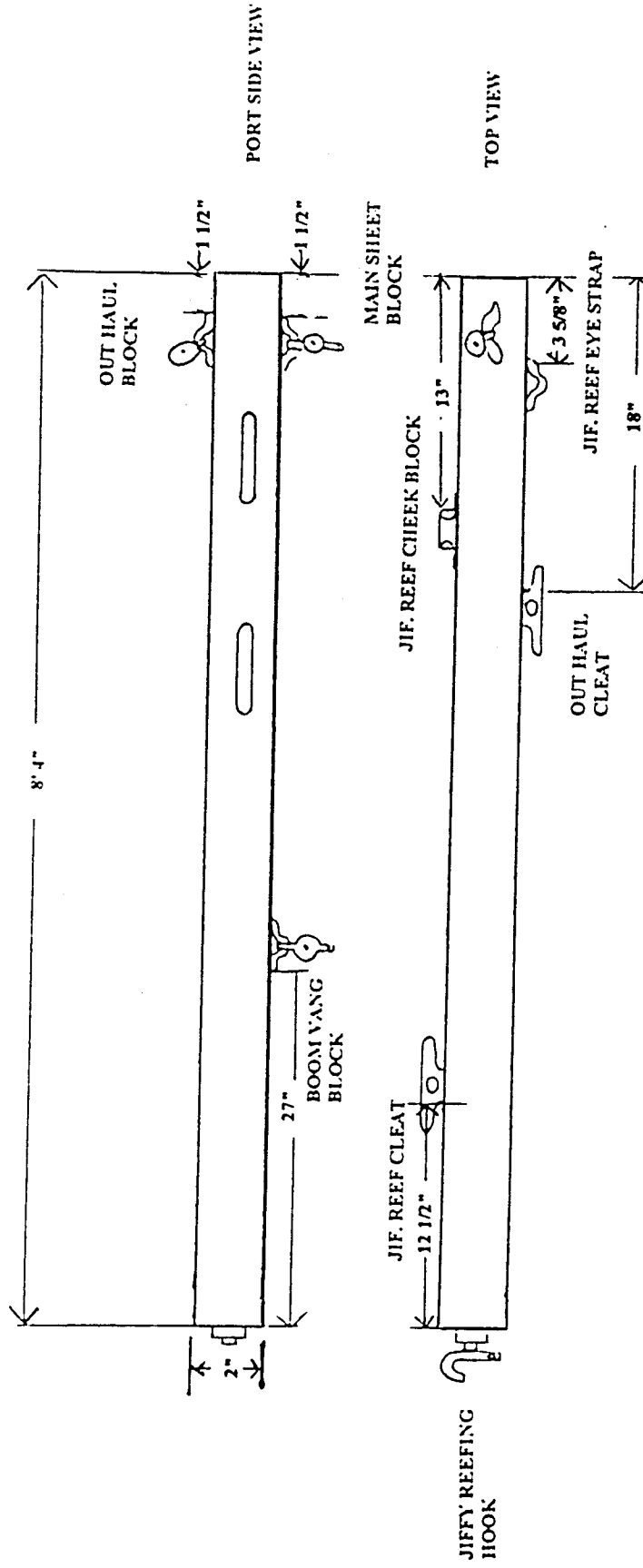

NOT TO SCALE
 ALL MEASUREMENTS ARE TO CENTER OF FIRST SCREW HOLE